

INDEKS

Potrebni alati/potreban hardver	1
Radne ploče/Nosivost	2
Mogućnosti ugradnje ormarića	3
Ugradnja nogu za izravnavanje (dodatna oprema)	4
Ugradnja stupova	5
Ugradnja visećih ploča	6
Spajanje ormarića zajedno	7
Spajanje ormarića/uklanjanje ladica	8
Mouting Woktopa	9
Spajanje stupova zajedno	10
Ugradnja zidnog ormarića	11
Ugradnja kutnog zidnog ormarića	12
Ugradnja LED svjetala (dodatna oprema)	13

Tools Required



Adjustable wrench

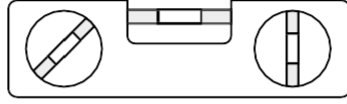

Magnetic Leveler

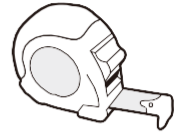

Tape Measure



Socket driver wrench



socket

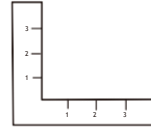

Set Square

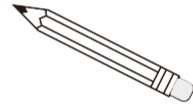

Pencil

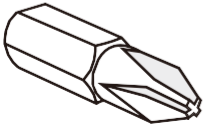

Phillips Bit



Phillips head screw driver



Cordless Power Drill



Masonry Bit

Hardwares Needed

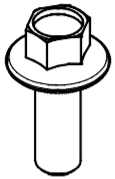

Hex Bolt (M6x16)



Nut (M6)



Plastic Pin



Hex Bolt (M8x16)

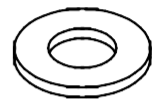

Washer (D8)



Spring Washer (D8)



Wood Screw (ST6x16)



Sunk Screw (M6x16)

Worktops



26" Worktop. Fits over 1 Cabinet



53" Worktop. Fits over 2 Cabinets

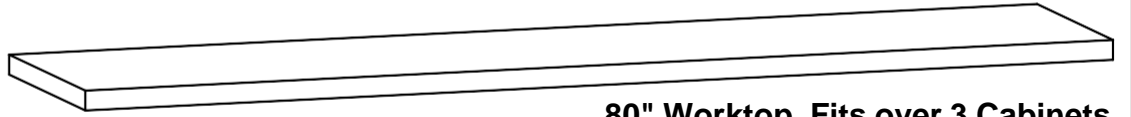

80" Worktop. Fits over 3 Cabinets

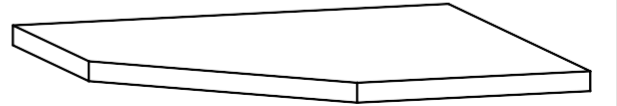

Corner Worktop

Nosivost

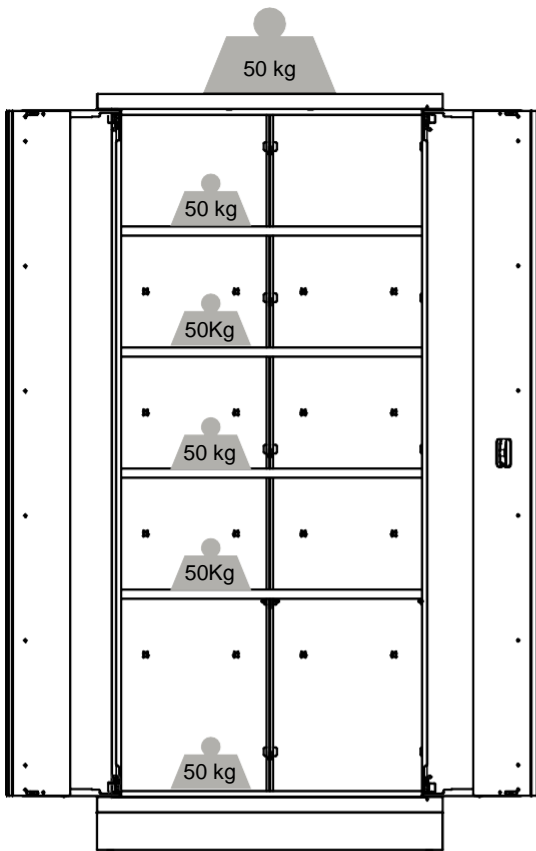

Ormarić s dvostrukim vratima Max 300Kg

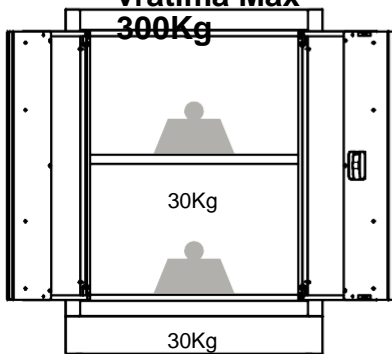

Donji

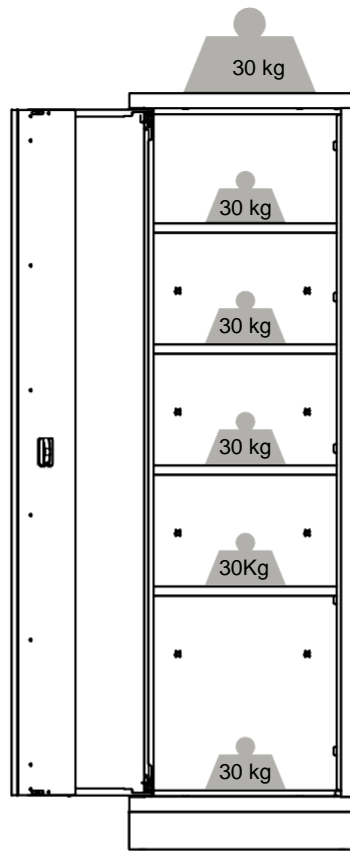

Ormarić s jednim vratima max 180Kg

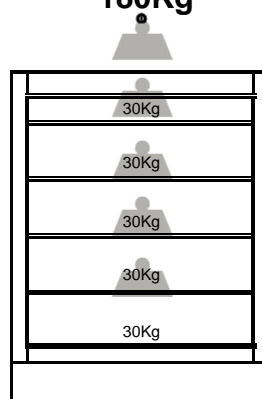

ormarić Max 60Kg

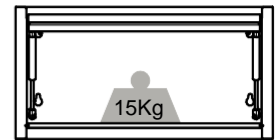

Zidni ormarić Max 15Kg

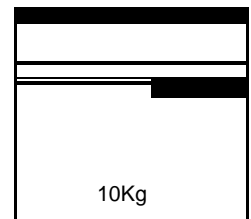

Viseća ploča Max 10Kg

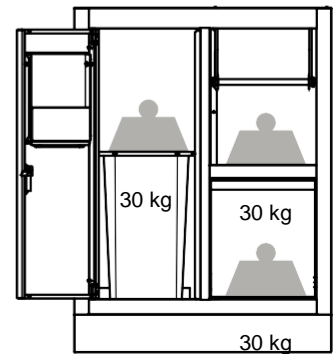

Ormar s ladicama max

150Kg

Ormar
za
kan
tu
za
sm
eće
Ma
x
90K
g

Mogućnosti ugradnje ormarića

i Važna informacija: Pročitajte prije početka instalacije.

- Layouts shown are only examples. Based on customer's purchase, cabinets can be configured in a variety of different layouts.
- Consider the location of electrical outlets when planning layout.

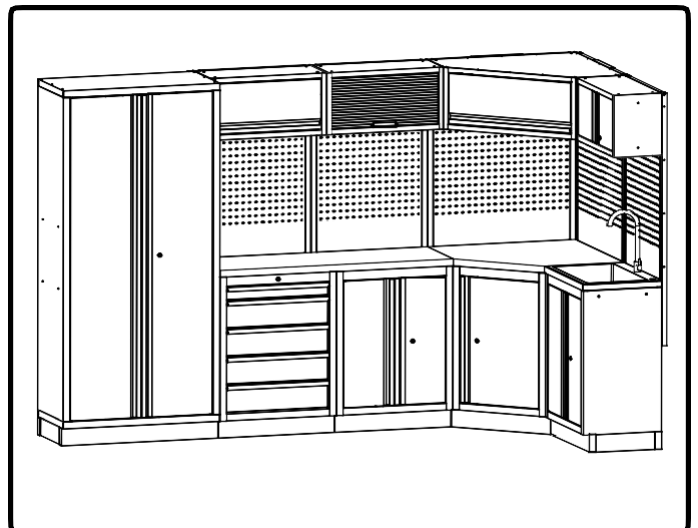
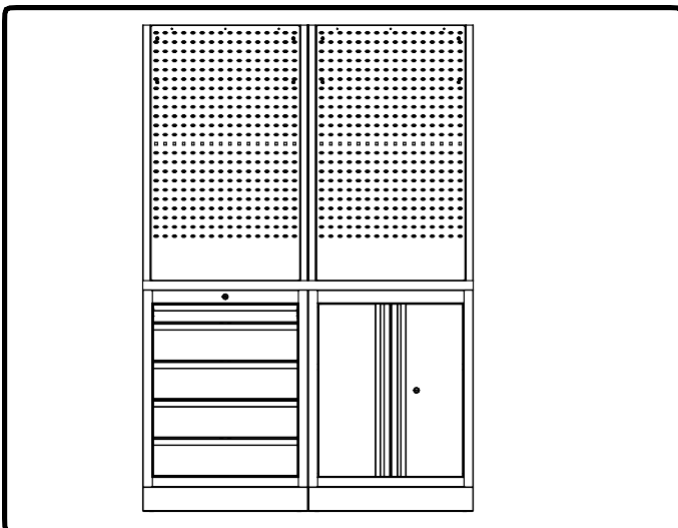
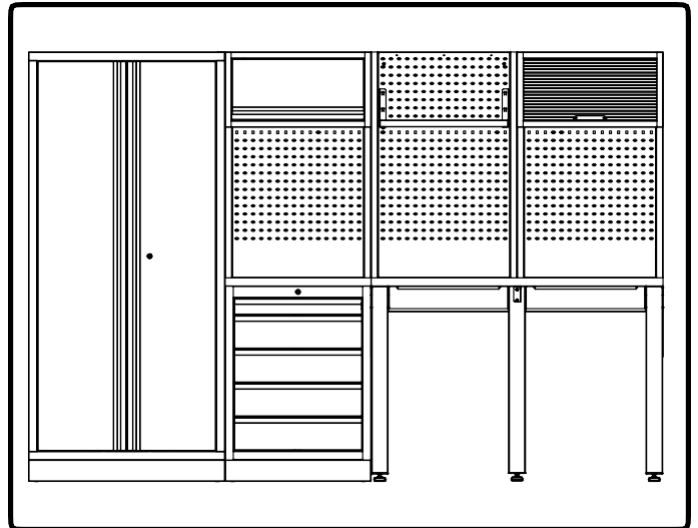
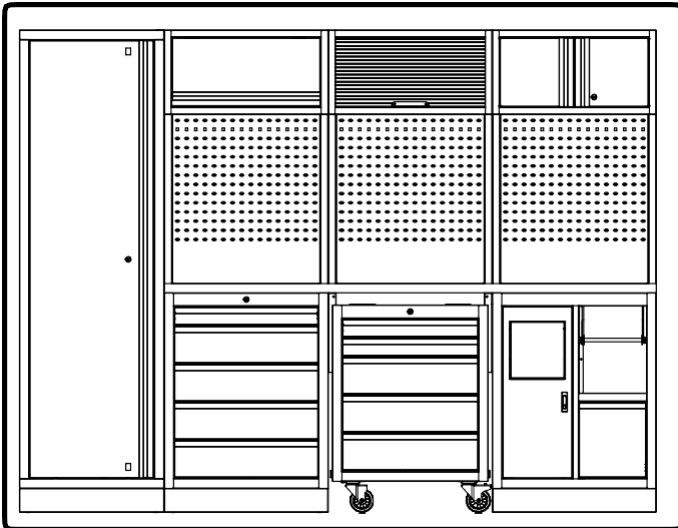
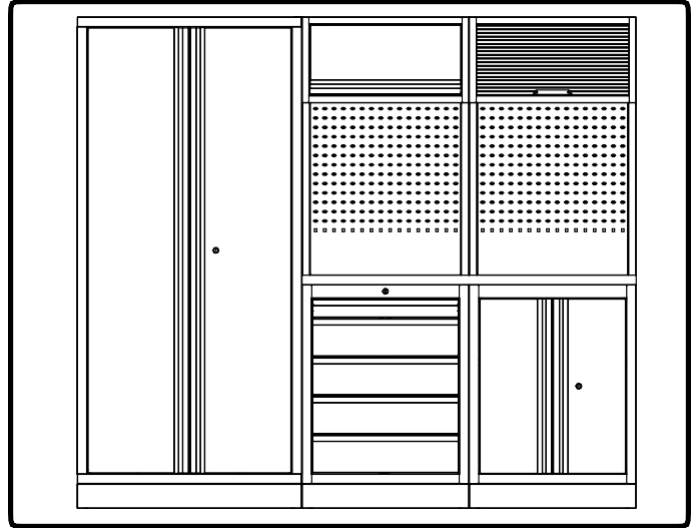

Ugradnja dodatne opreme

i Započnite pričvršćivanjem nogu za izravnavanje (dodatni pribor). Preskočite i okrenite stranicu 5 ako nisu kupljene noge za izravnavanje.

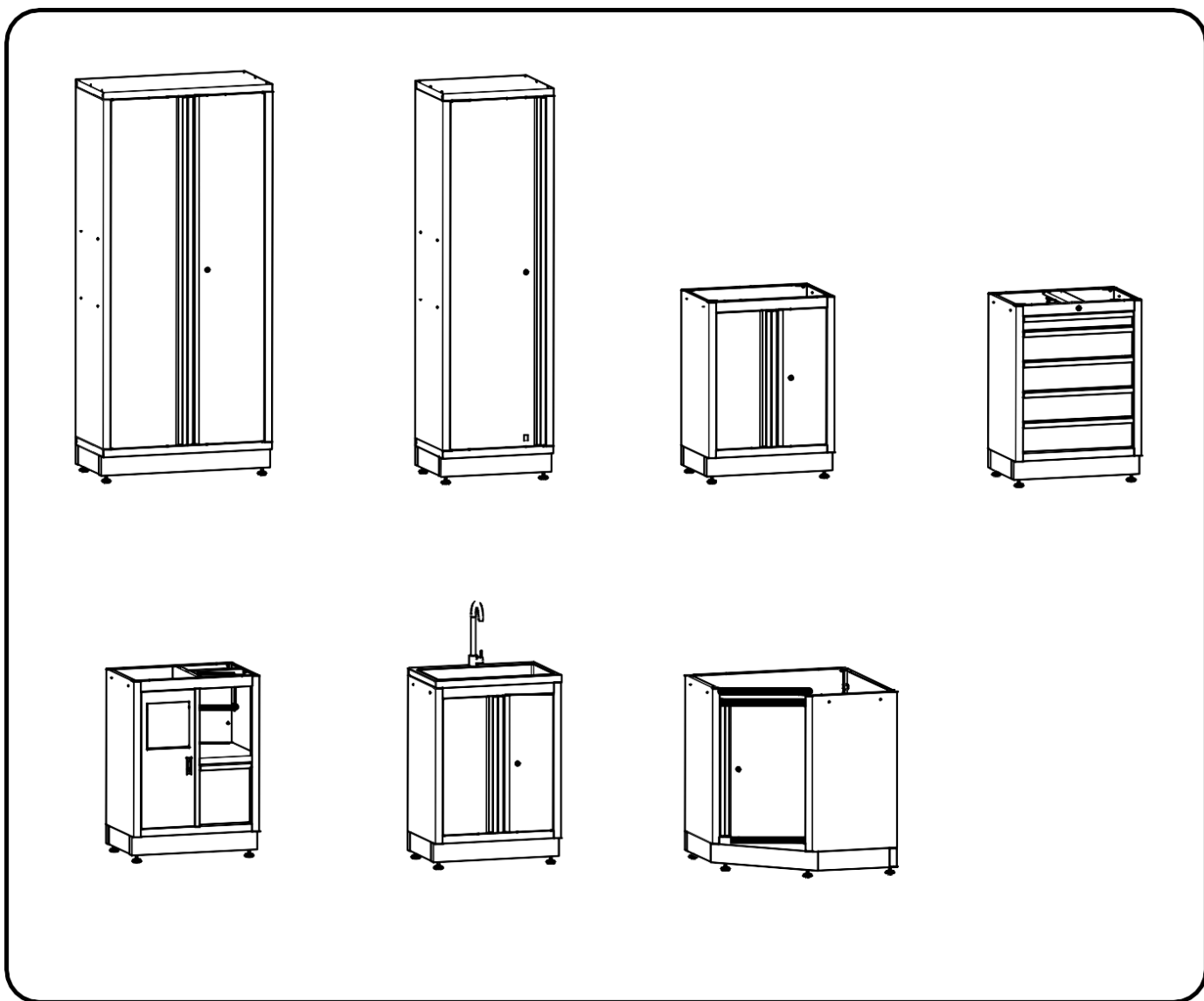
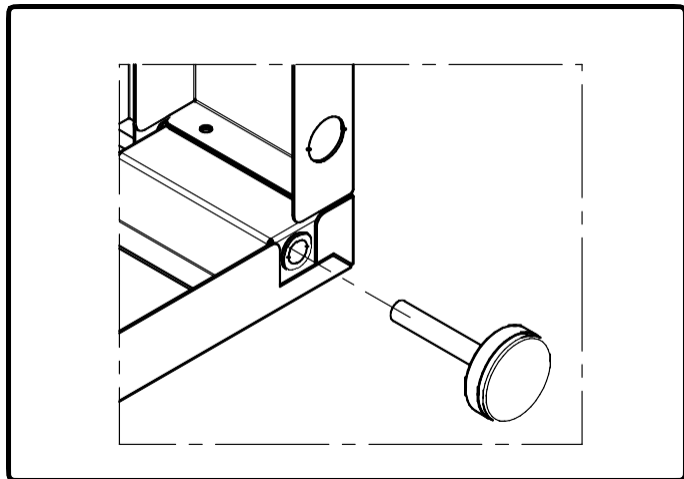
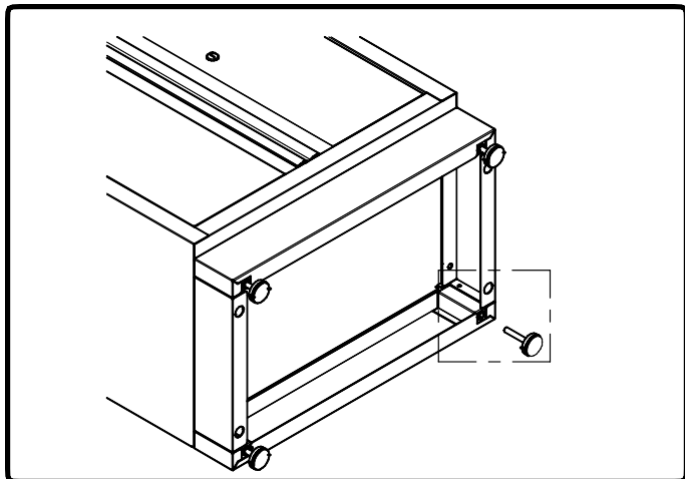

Ugradnja stupova

i Potrebni hardveri.

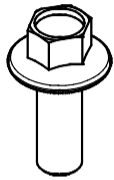

Hex Bolt
(M6x16)



Nut
(M6)

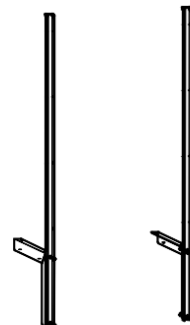
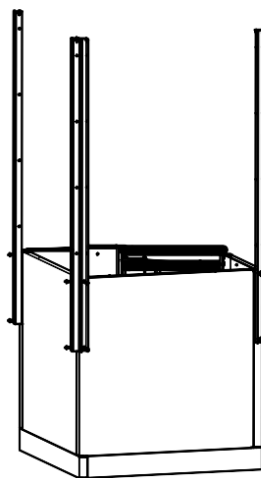
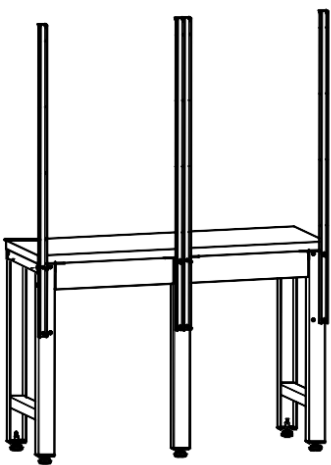
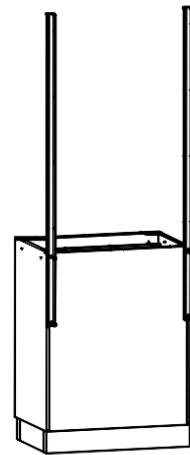
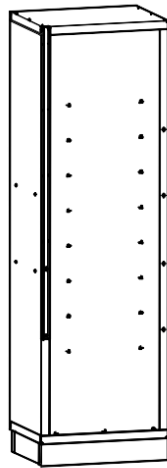
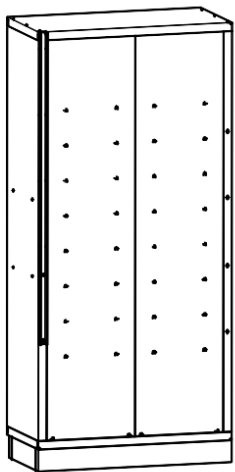
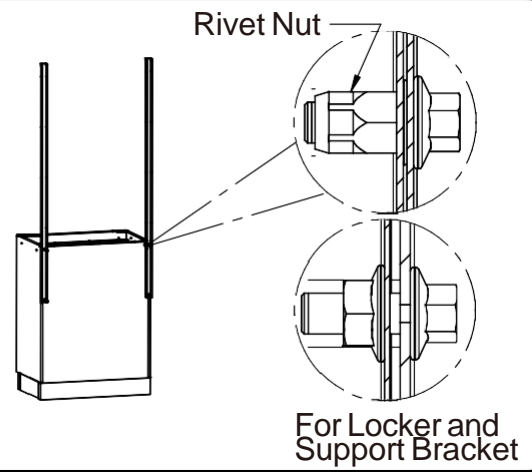

Ugradnja visećih ploča

i Potrebni hardveri.

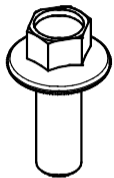

**Hex Bolt
(M6x16)**



**Nut
(M6)**

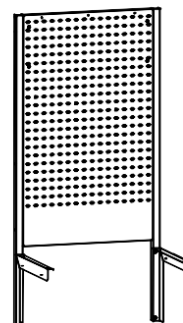
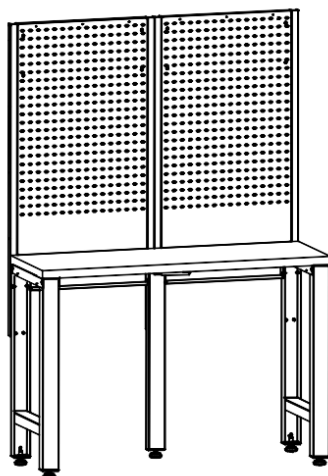
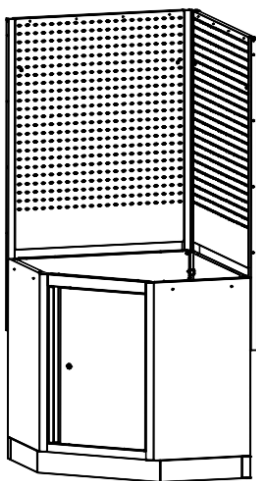
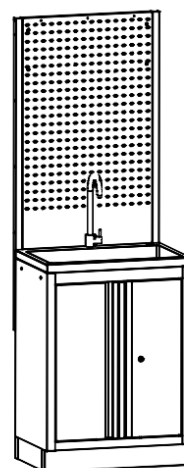
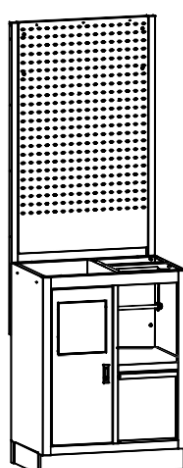
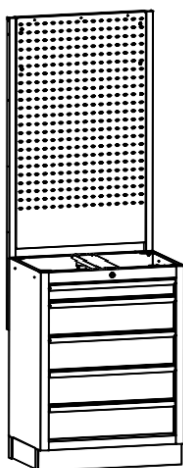
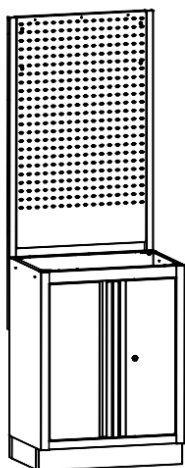
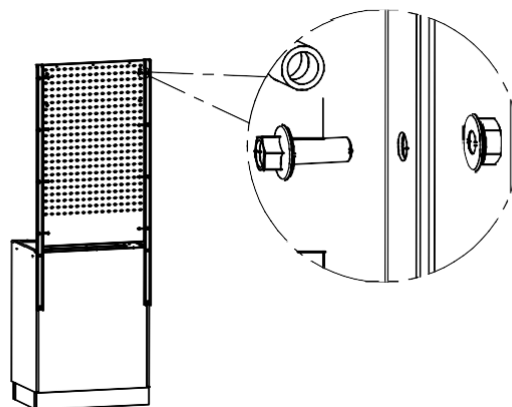

Spajanje ormarića zajedno

Postavite i pričvrstite preostale ormare na zid. Ugradite ormare jedan po jedan.

Podesite četiri noge za izravnavanje kako biste bili sigurni da je ravnomjeran prema tlu.

Hardwares Needed.

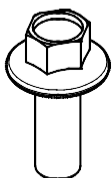

**Hex Bolt
(M6x16)**



**Nut
(M6)**

Pričvrstite ormarić i donji ormarić

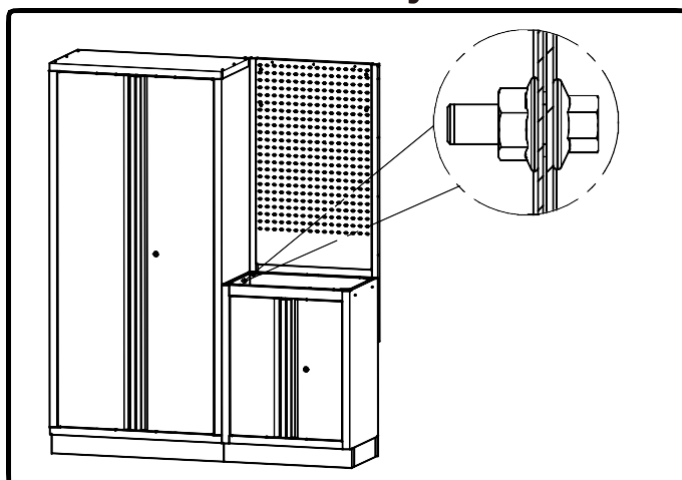

Pričvrstite ladice i donje ormariće

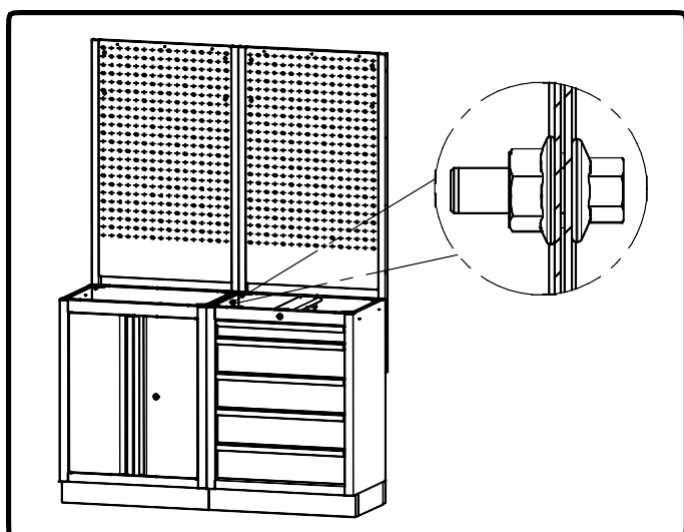

Pričvrstite sudoper i donje ormariće

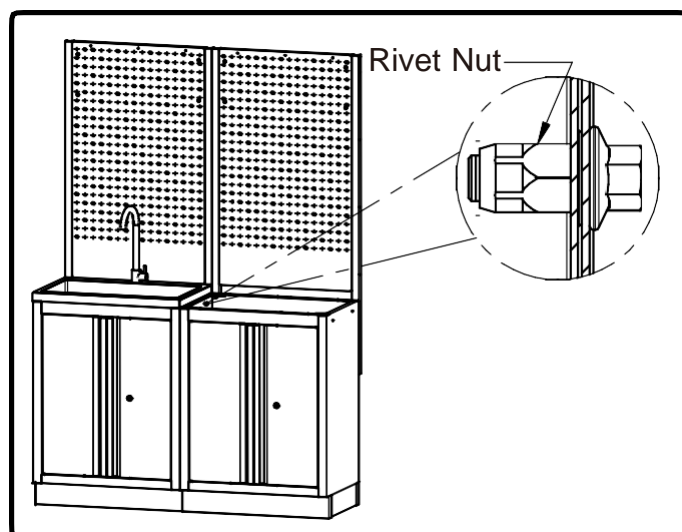

Pričvrstite kutne i donje ormariće

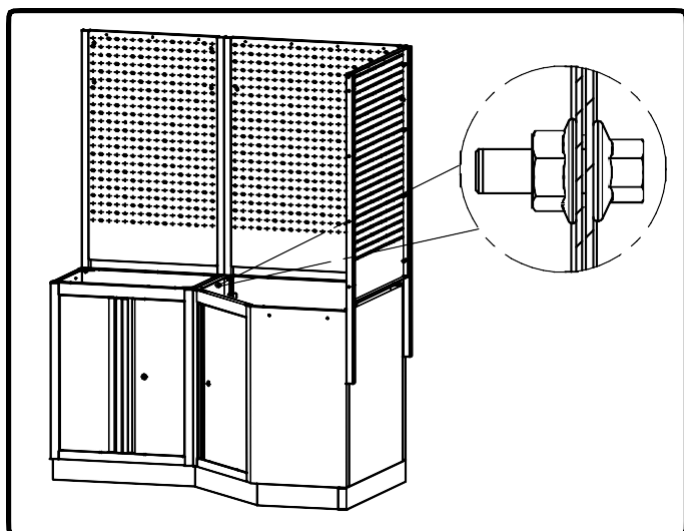

Pričvrstite donji ormarić i potporne nosače

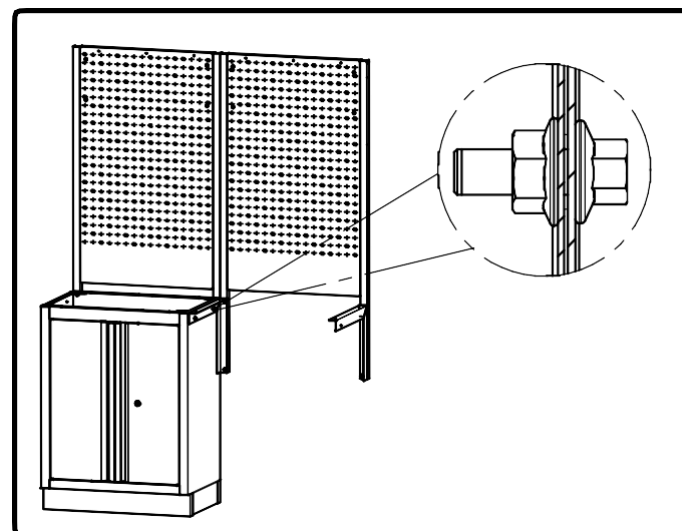

Spajanje ormarića zajedno

Pričvrstite donji ormarić i radni stol

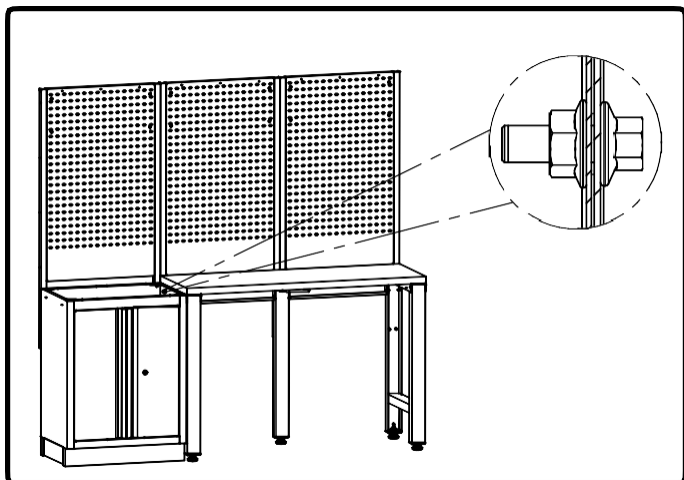

Uklanjanje ladica

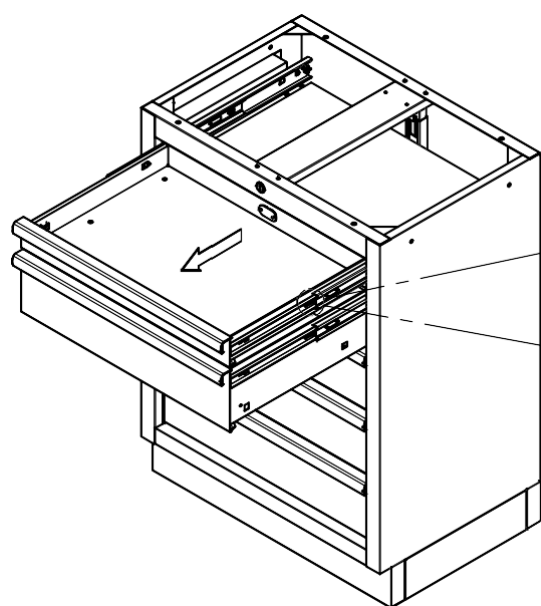

Lijeva strana

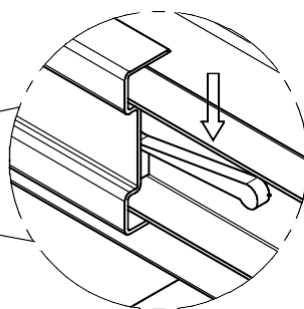

Desna strana

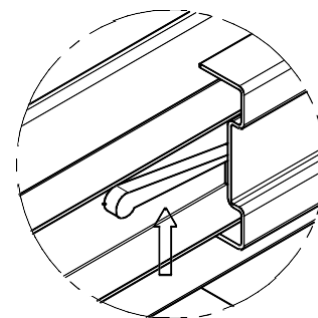

Pritisnite bočne dijelove ladice kao što je prikazano istovremeno kako biste uklonili ladice.

Mouting Woktopa

i Potrebni hardveri.

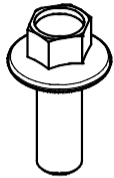

**Hex Bolt
(M6x16)**

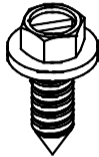

**Wood Screw
(ST6x16)**

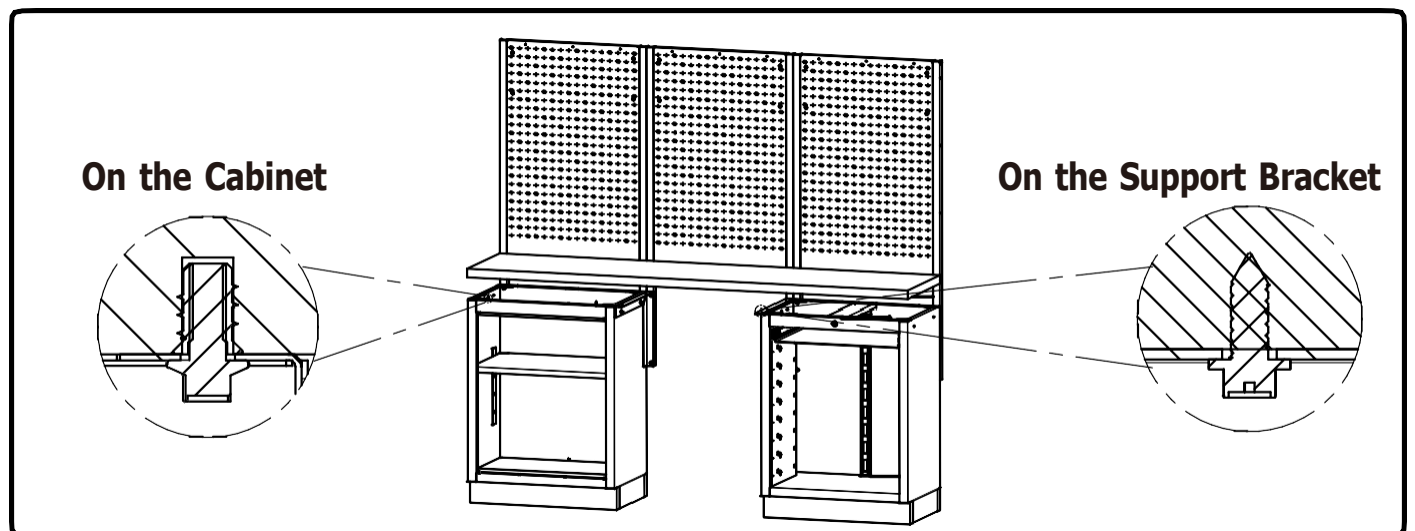
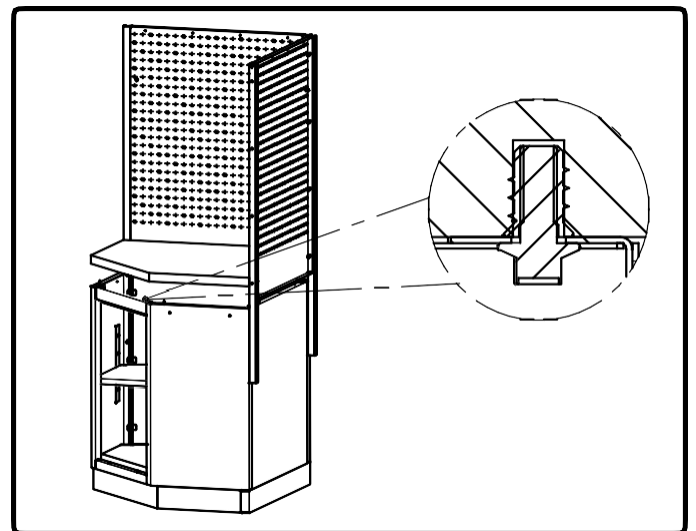
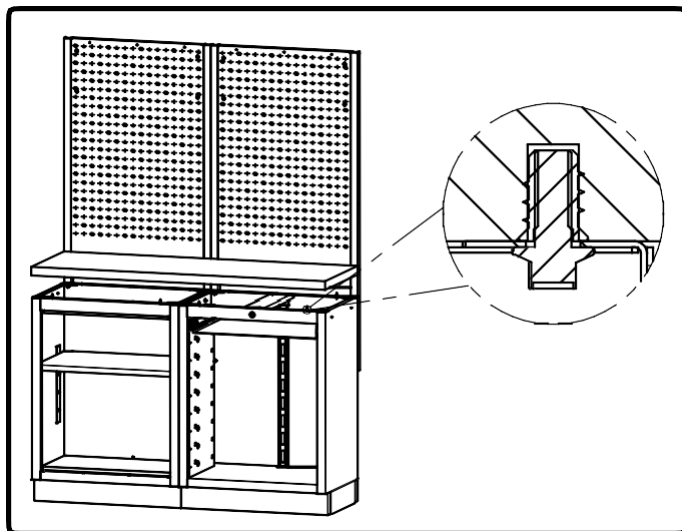
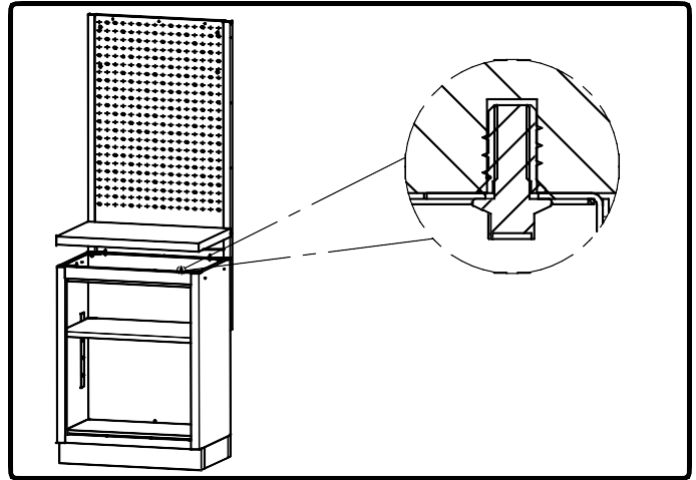

On the Cabinet

On the Support Bracket

Spajanje stupova zajedno

i Potrebni hardveri.

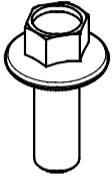

**Hex Bolt
(M6x16)**



**Nut
(M6)**

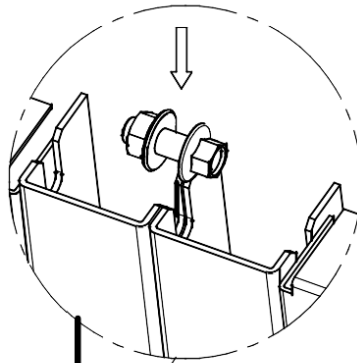

**No need to fasten
in the corner.**

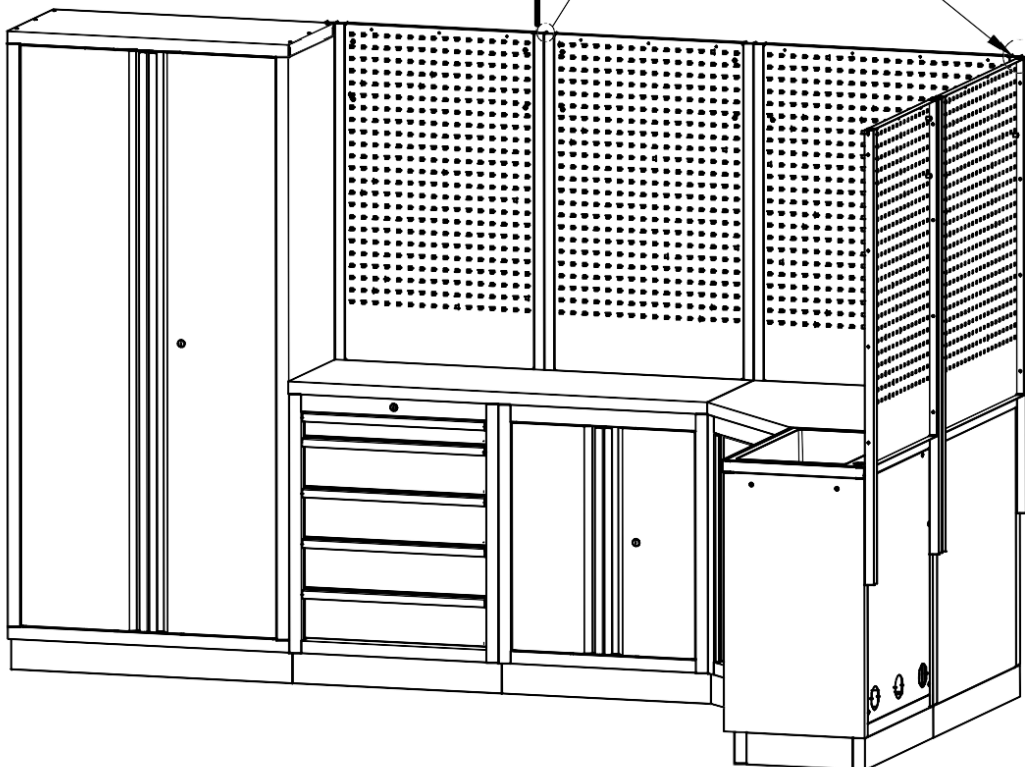

Ugradnja zidnog ormarića

i Potrebni hardveri.

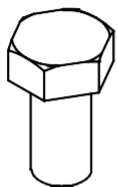

Hex Bolt
(M8x16)

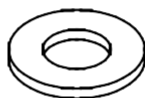

Washer
(D8)



Spring Washer
(D8)

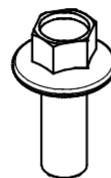

Hex Bolt
(M6x16)



Nut
(M6)

Unaprijed sastavite vijak i podlošku na ploči

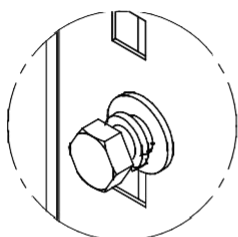

Objesite na zidni ormarić i pričvrstite vijak.

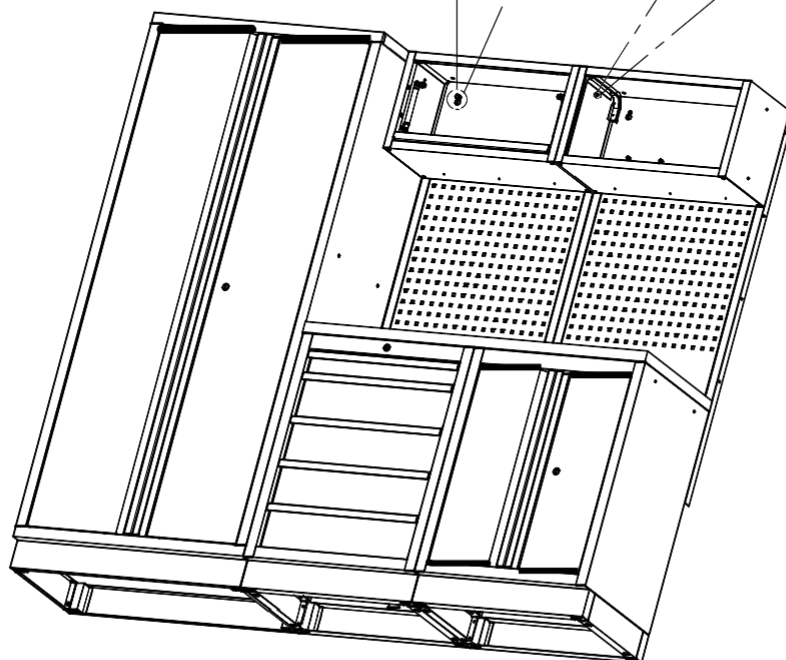
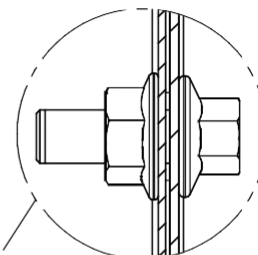
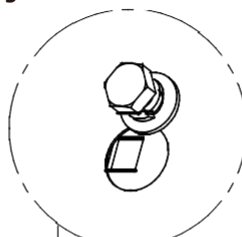

NAPOMENA: Ovaj korak je za 3 vrste zidnih ormarića.

Ugradnja kutnog zidnog ormarića

i Potrebni hardveri.

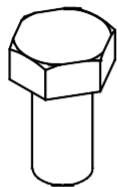

**Hex Bolt
(M8x16)**



**Washer
(D8)**



**Spring Washer
(D8)**



**Sunk Screw
(M6x16)**

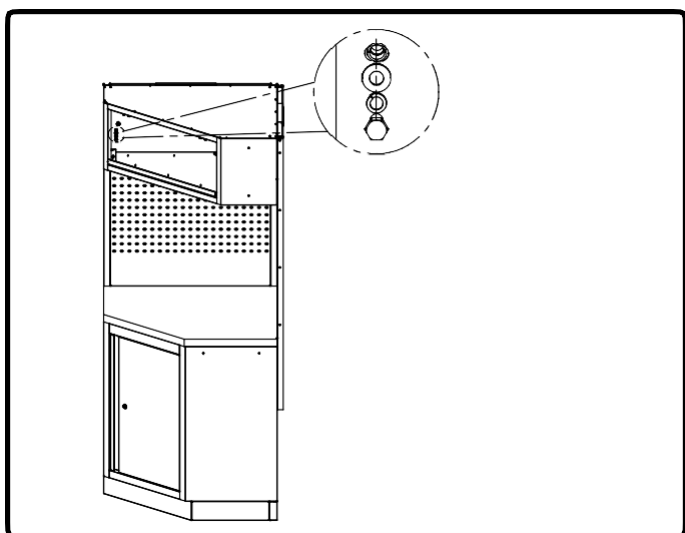
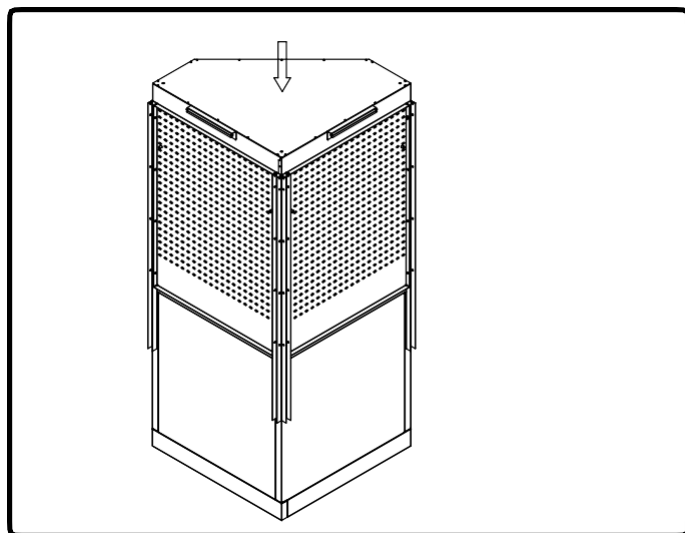
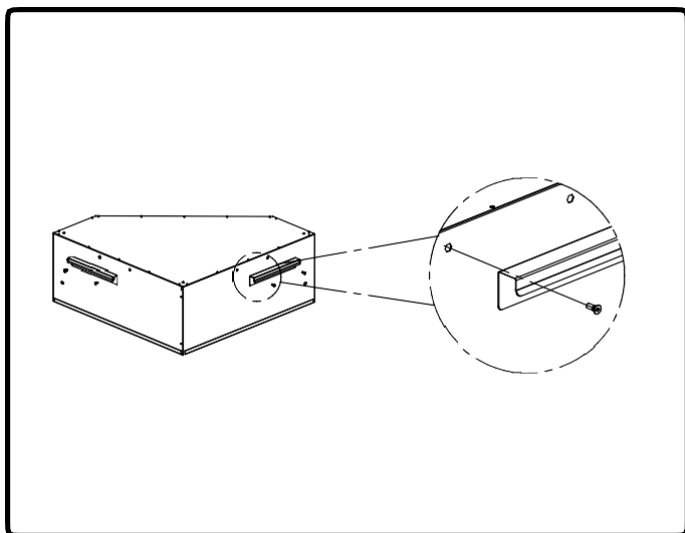

Ugradnja LED svjetla (dodatni pribor)

Zalijepite LED svjetlo na dno zidnog ormarića.

